

POZZA

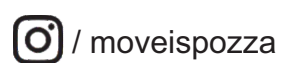

PE 02



Rua Fioravante Pozza, 404-i - Bento gonçalves, RS - Brasil

Atenção!

- Parabéns, você está adquirindo um produto com a qualidade Pozza.
- **IMPORTANTE!** Para que o produto não perca a garantia, solicitamos observar atentamente as orientações de montagem.
- Aconselhamos utilizar a embalagem para forrar o chão, afim de não danificar o produto.

Attention!

- Congratulations, you are acquiring a product with Pozza quality.
- **IMPORTANT!** In order to keep the guarantee of the product, we request to carefully observe the assembly instructions.
- We advise to use the package to protect the floor in order to prevent damages.

Atención!

- Felicitaciones, usted está adquiriendo un producto con la calidad Pozza.
- **IMPORTANTE!** Para que el producto no pierda la garantía, pedimos que lea atentamente las instrucciones.
- Si recomienda utilizar la caja de cartón para cubrir el piso de tal manera que no se dañe el producto.

Limpeza

- Para manutenção e melhor conservação do produto cromado, não se deve deixar a superfície exposta à umidade e ao acúmulo de pó.
- Não utilizar panos úmidos, produtos químicos e materiais ásperos na limpeza. A cada 30 dias limpar o produto com flanela e aplicar cera de polir.

Cleaning

- For maintenance and better preservation of the chrome product, the surface must not be exposed to humidity and to the accumulation of dust.
- Do not use damp cloths, chemicals and rough materials for cleaning. Every 30 days, clean the product with flannel and apply polishing wax.

Limpieza

- Para el mantenimiento y mejor conservación del producto cromo no se debe dejar la superficie expuesta a la humedad ya la acumulación de polvo.
- No utilizar paño húmedo, productos químicos y materias ásperas en la limpieza. Cada 30 días limpiar el producto con franela y aplicar cera de pulir.

Ferragens Hardwares Herrajes



EF 000033 x 4
8x30



EF 000094 X 6



EF 000216 X 6

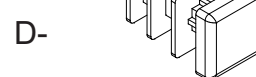

Ponteiras x 12
Plastic tips x 12
Puntas x 12



EF 000818 X 8
4,5 X 30 CF PRETO



EF 000819 x 8
4,5X16 CF PRETO



EF 000820 x 16
6X12 CP PRETO



EF 000763 x 1

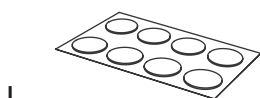

TAPA FUROS x 6
STICKER x 6
TAPAS PLÁSTICAS x 6



GIZ x 01
CHALK x 01
TIZA x 01

Peças / Pieces / Piezas

PEÇA	DESCRIÇÃO	QUANT.	PART	DESCRIPTION	QTY	PIEZA	DESCRIPCIÓN	CANTIDAD
001	BASE	1	001	BASE	1	001	BASE	1
002	TAMPO	1	002	TOP	1	002	TAPA	1
003	PRATELEIRA SUPERIOR	1	003	UPPER SHELF	1	003	REPISA SUPERIOR	1
004	PRATELEIRA INFERIOR	1	004	LOWER SHELF	1	004	REPISA INFERIOR	1
005	COSTA	1	005	BACK	1	005	REVÉS	1
006	ESTRUTURA METÁLICA	2	006	METAL STRUCTURE	2	006	ESTRUCTURA METÁLICA	2
007	TRAVESSA	4	007	TRAVERSE </td <td>4</td> <td>007</td> <td>TRAVESAÑO</td> <td>4</td>	4	007	TRAVESAÑO	4

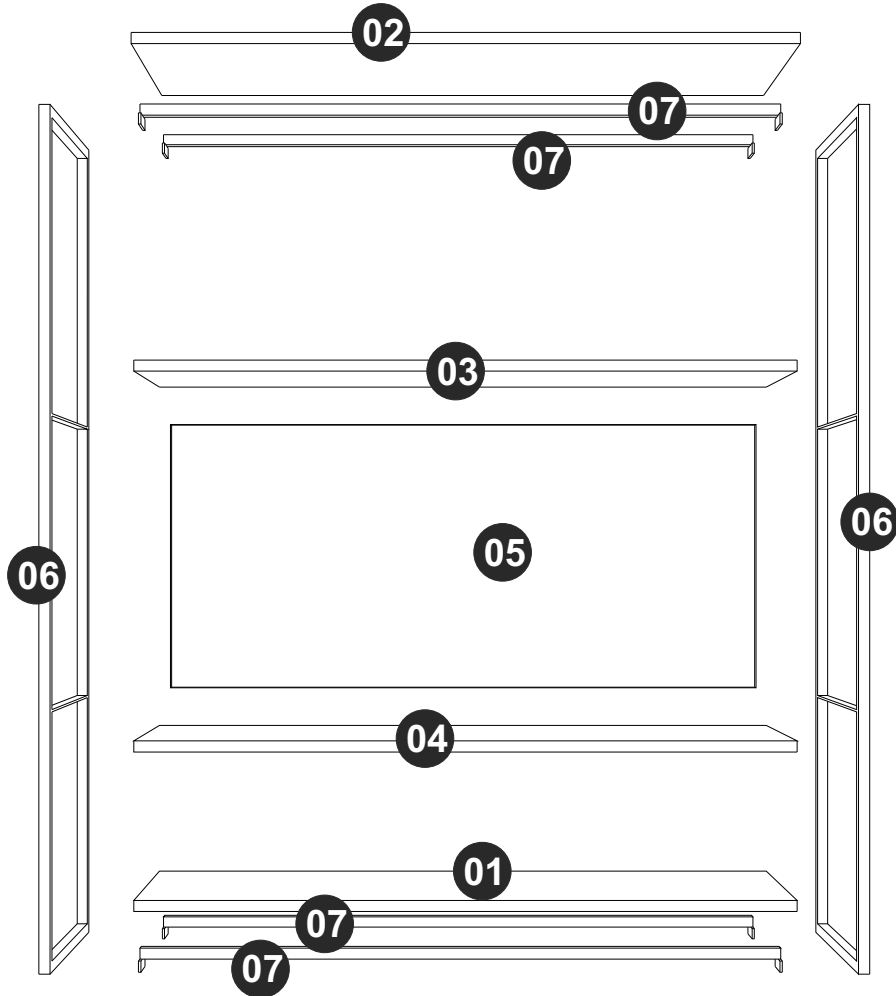

A = 10 KG - 22.04 LB

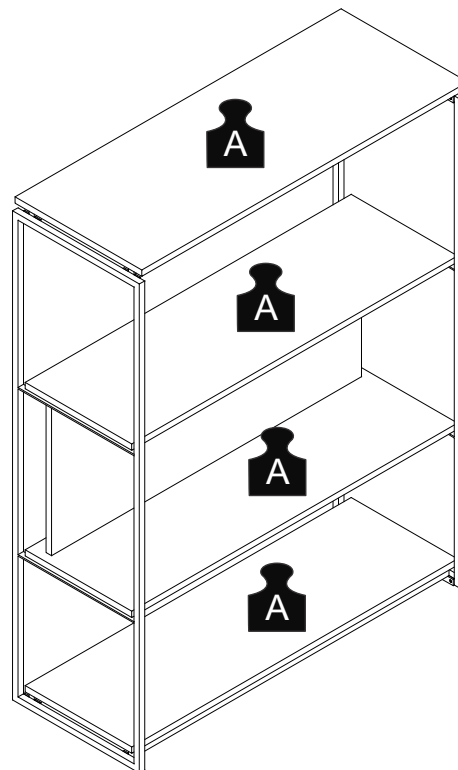

PASSO 1 / STEP 1 / PASO 1

Fixe a ferragem B nas peças 03 e 04.
Attach hardware B into pieces 03 and 04.
Fije el herraje B en las piezas 03 y 04.

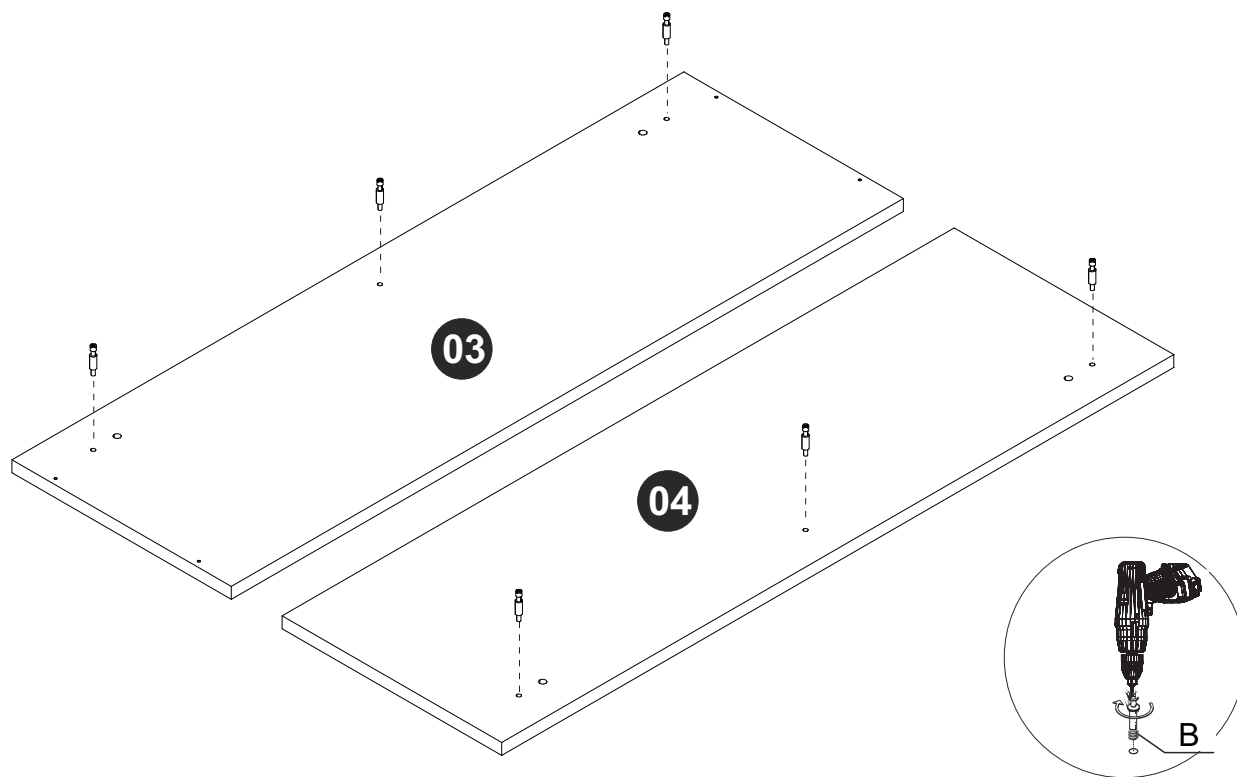

PASSO 2 / STEP 2 / PASO 2

Insira a ferragem A na peça 05.
Insert hardware A into piece 05.
Añade el herraje A en la pieza 05.

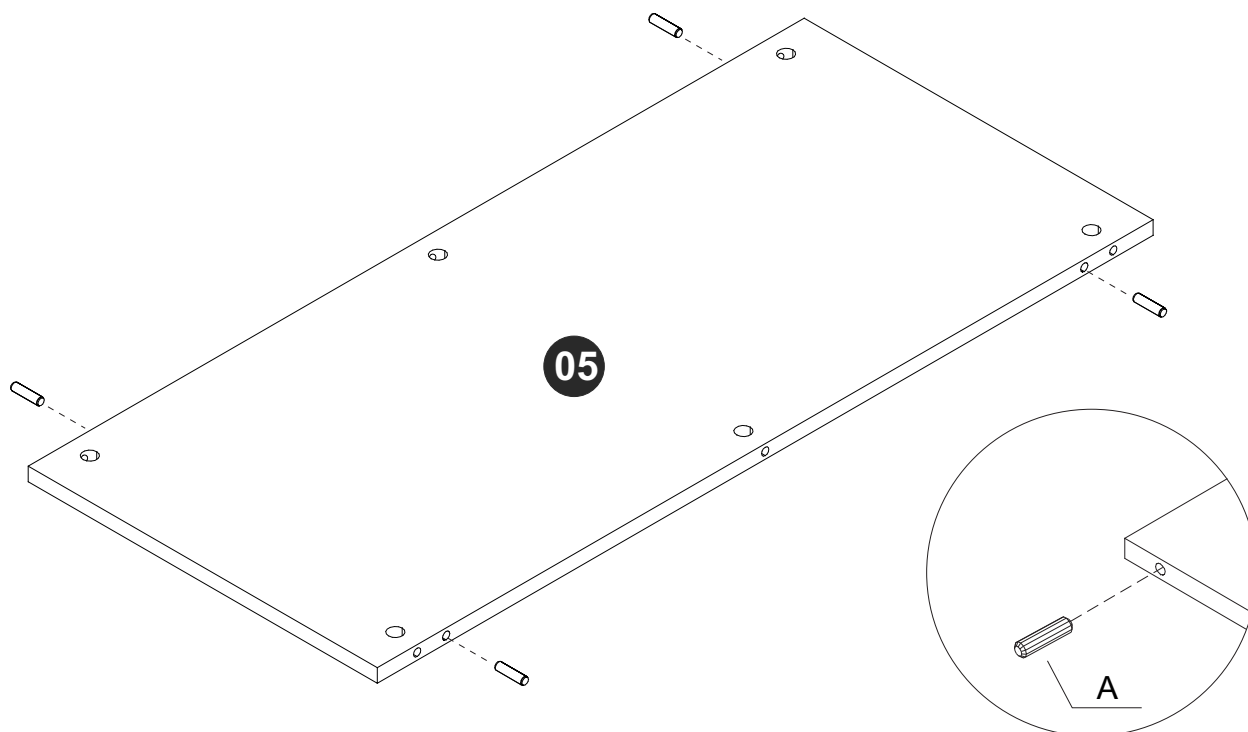

PASSO 3 / STEP 3 / PASO 3

Encaixe a ferragem D nas peças 07.

Fit hardware D to the pieces 07.

Junte el herraje D en las piezas 07.

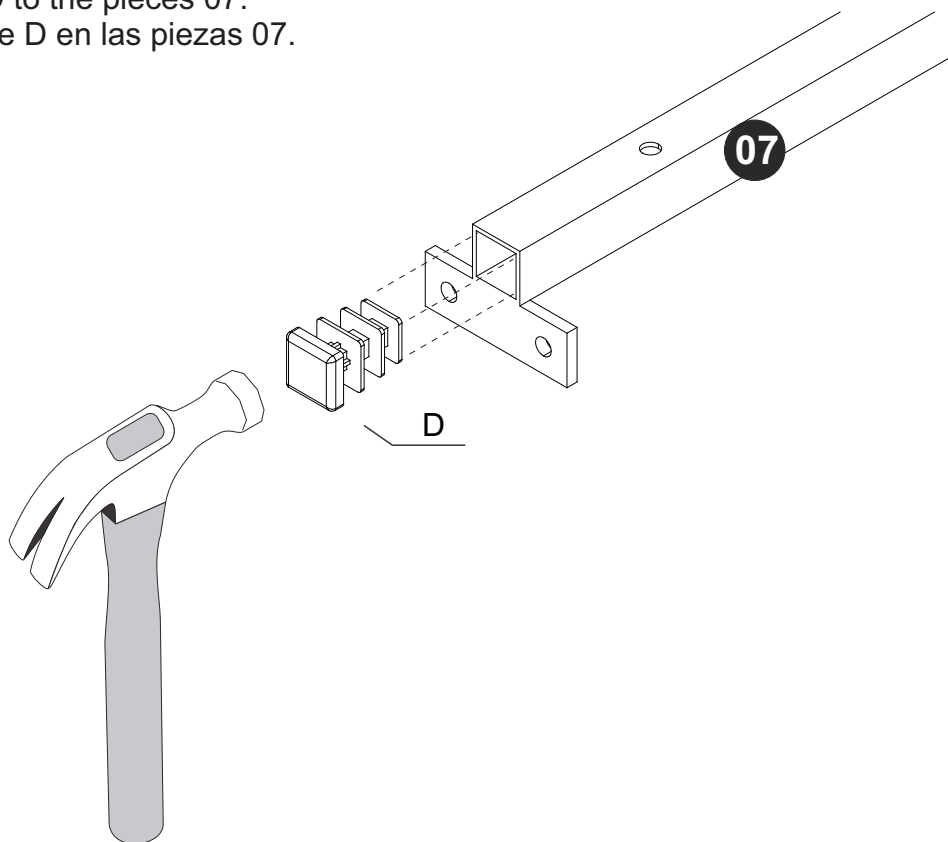

PASSO 4 / STEP 4 / PASO 4

Conecte as peças 03, 04 e 05, insira a ferragem C e gire para apertar.

Connect pieces 03, 04 and 05, insert hardware C and turn to tighten.

Junte las piezas 03, 04 y 05, añada el herraje C y gire para apretar.

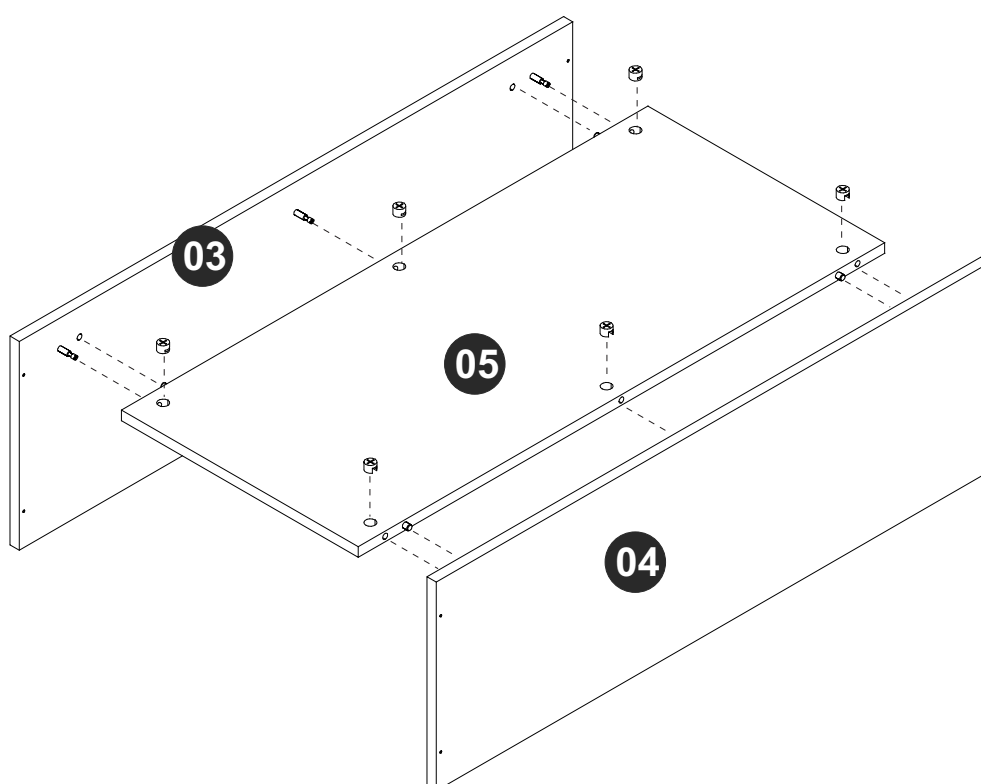

PASSO 5 / STEP 5 / PASO 5

Conecte a peça 06 à parte montada no passo anterior utilizando a ferragem F.
Connect piece 06 to the part assembled into the previous step using hardware F.
Junte la pieza 06 a la parte armada en el paso anterior utilizando el herraje F.

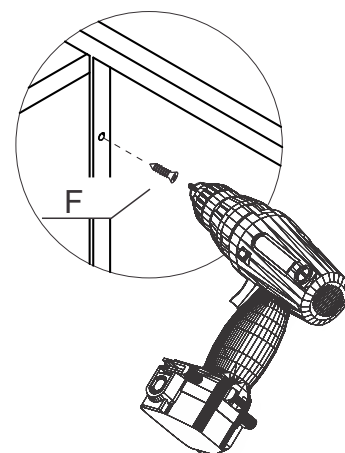
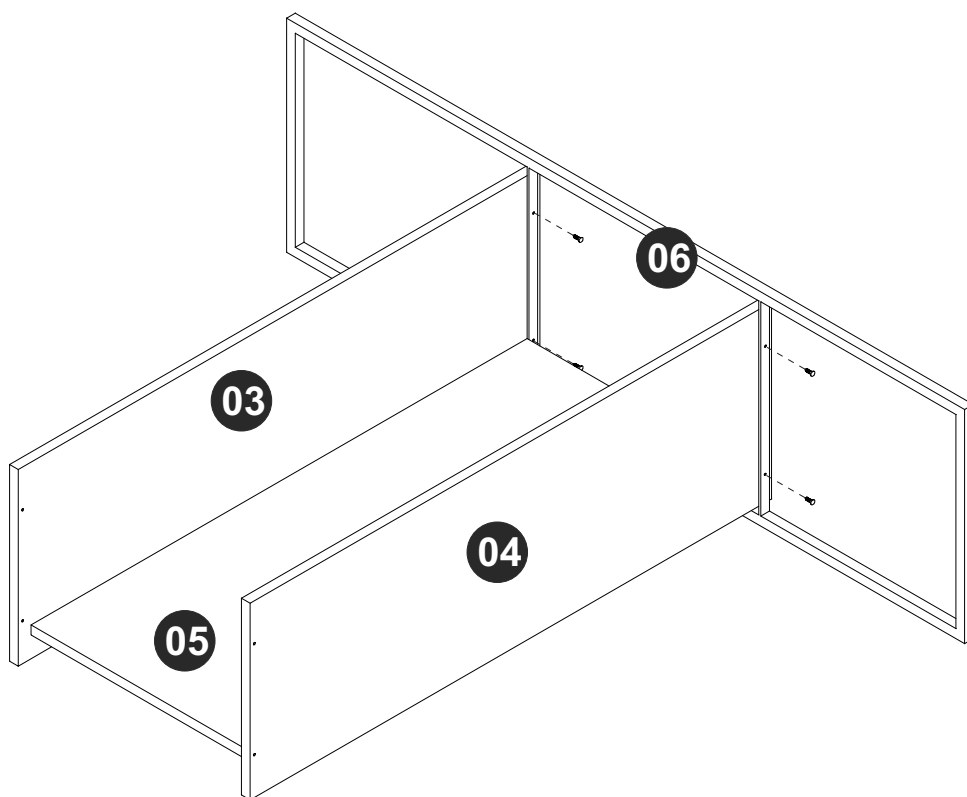

PASSO 6 / STEP 6 / PASO 6

Conecte a peça 06 à parte montada no passo anterior utilizando a ferragem F.
Connect piece 06 to the part assembled into the previous step using hardware F.
Junte la pieza 06 a la parte armada en el paso anterior utilizando el herraje F.

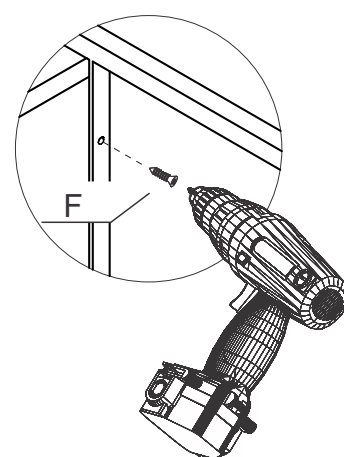
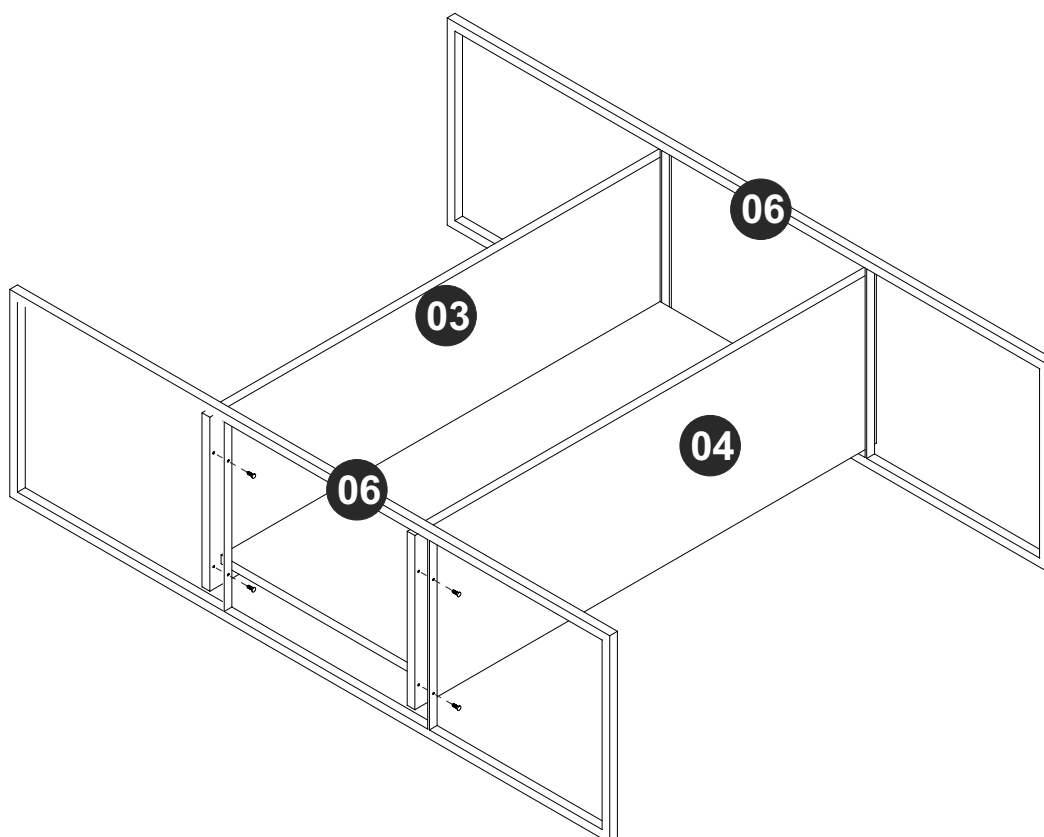

PASSO 7 / STEP 7 / PASO 7

Fixe as peças 07 ao móvel montado utilizando as ferragens G e H.
Attach pieces 07 at the assembled furniture using hardwares G and H.
Fije las piezas 07 al mueble armado utilizando los herrajes G y H.

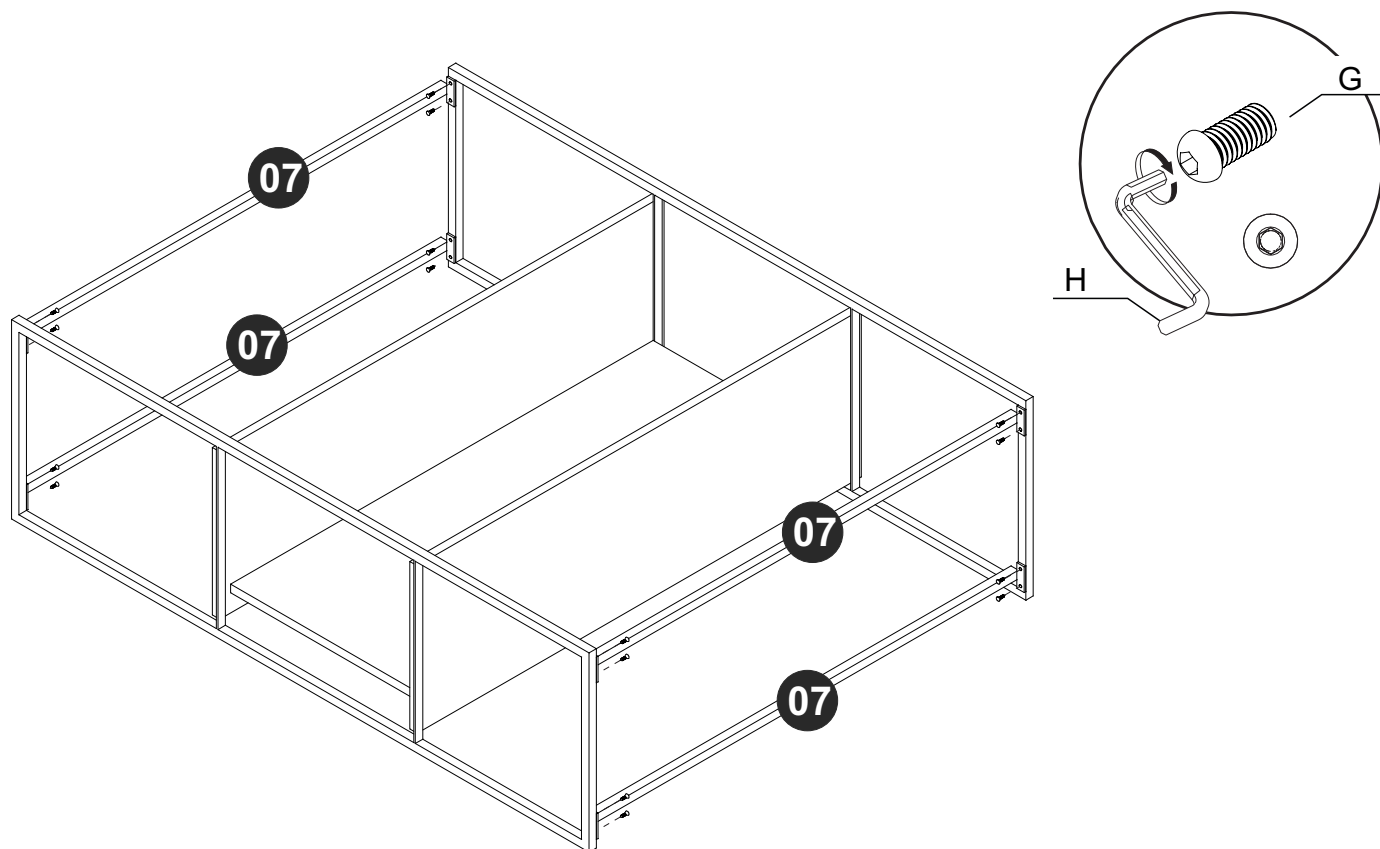

PASSO 8 / STEP 8 / PASO 8

Fixe as peças 01 e 02 ao móvel montado utilizando a ferragem E.
Attach pieces 01 and 02 at the assembled furniture using hardware E.
Fije las piezas 01 y 02 al mueble armado utilizando el herraje E.

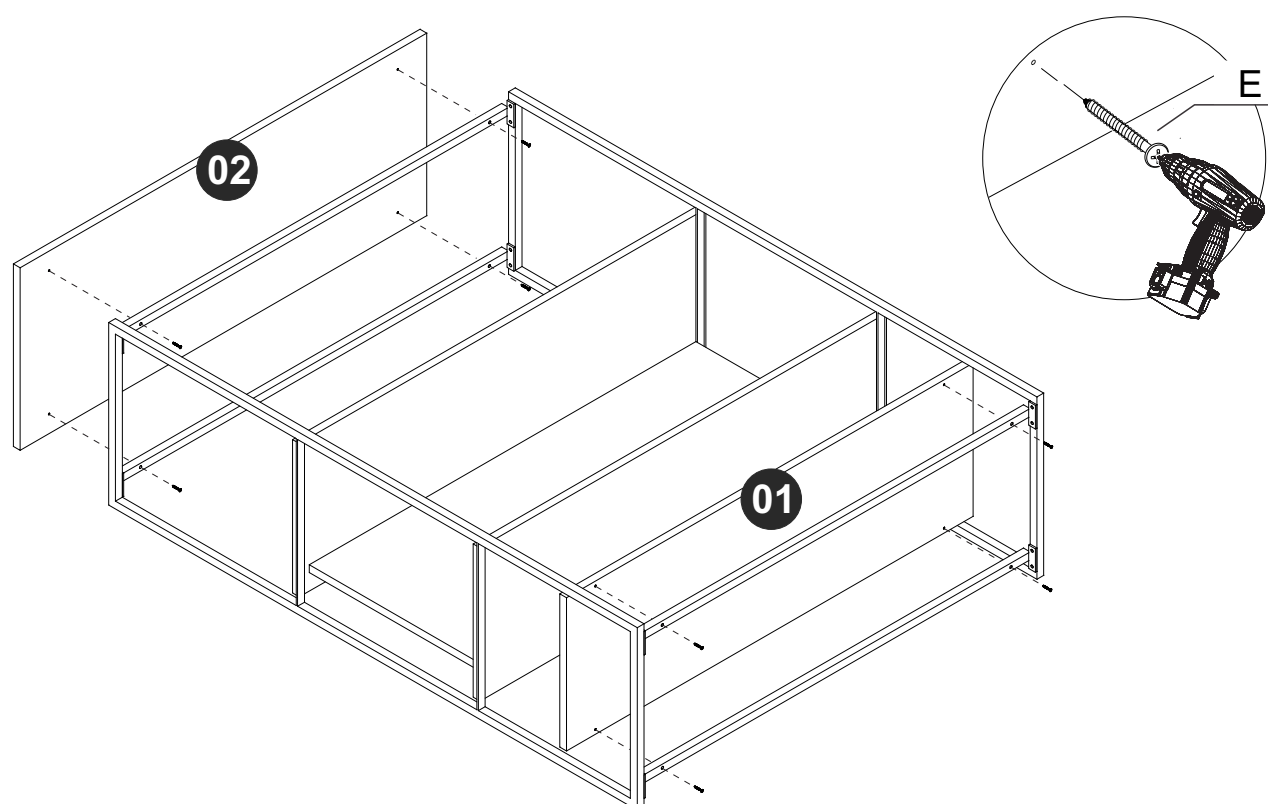

PASSO 9 / STEP 9 / PASO 9

Encaixe a ferragem D nas peças 06.

Fit hardware D into pieces 06.

Junte el herraje D en las piezas 06.

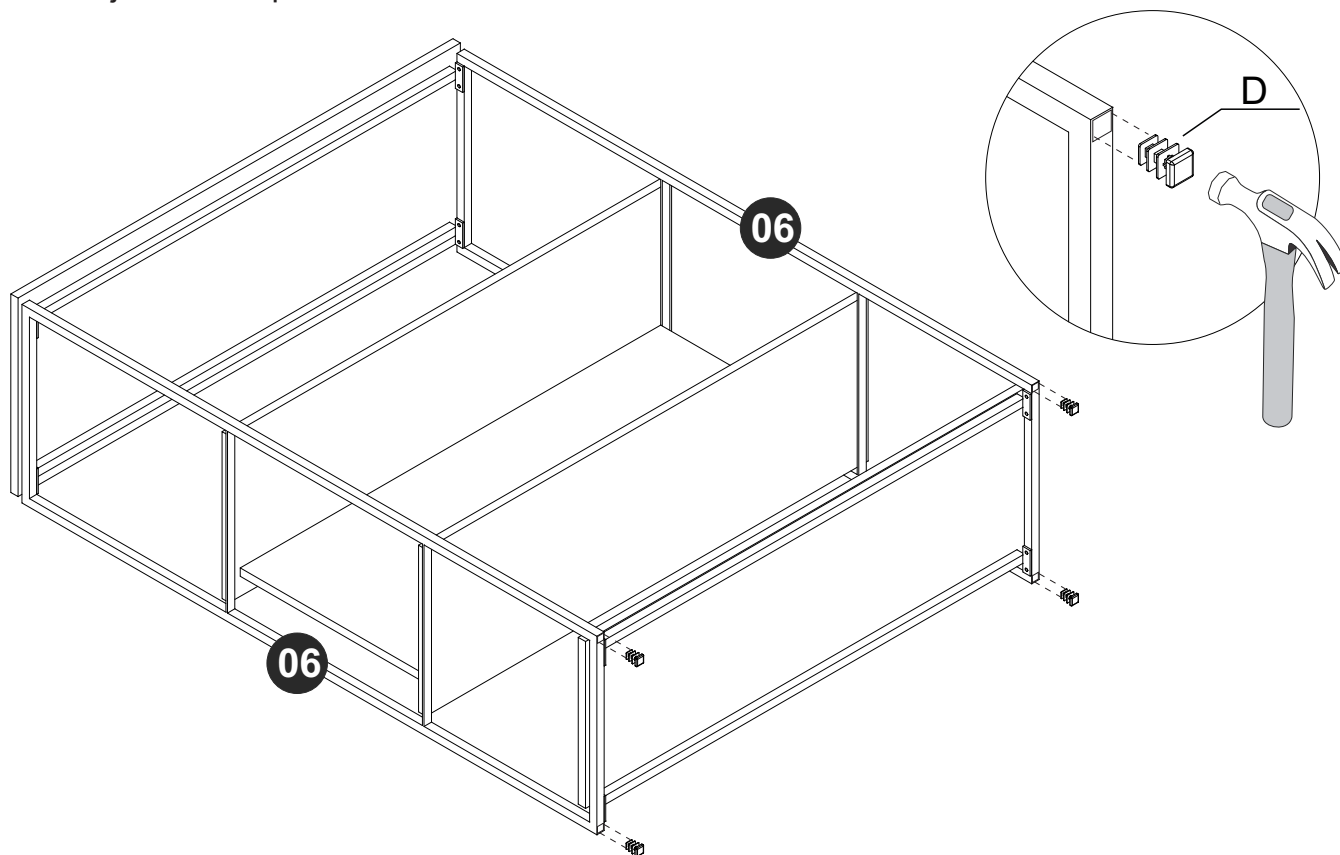

PASSO 10 / STEP 10 / PASO 10

Utilize o giz para dar o acabamento final ao produto.

Utilize os tapa furos para cobrir os parafusos aparentes.

Use the chalk to give the final finish on the product.

Use the sticker to cover the apparent screws.

Utilice la tiza para dar el acabado final al producto.

Utilice los tapa huecos para cubrir los tornillos aparentes.

