



**MANUAL DE MONTAGEM
ASSEMBLY INSTRUCTIONS
INSTRUCCIONES DE MONTAJE**

COD BR: BLC 63

Sumário Summary Resumen

Introdução Introduction Introducción	3
Antes de começar Before starting Antes de comenzar	4
Evite acidentes Avoid accidents Evitar accidentes	4
Dimensões e ferramentas Dimensions and tools Dimensiones y herramientas	5
Identificação das peças Identifying parts Identificación de las piezas	6
Acessórios incluídos na caixa Hardware included in box Accesorios incluidos en la caja	7
Montagem do móvel Furniture assembly Montaje del mueble	8

Introdução Introduction Introducción

Leia atentamente este manual e siga os passos indicados para que o produto não perca a garantia e também para uma perfeita montagem.

Read this manual and follow the steps in order to keep the guarantee and also for the perfect fit.

Lea este manual y siga los pasos para que el producto no pierda la garantía y también para el ajuste perfecto.

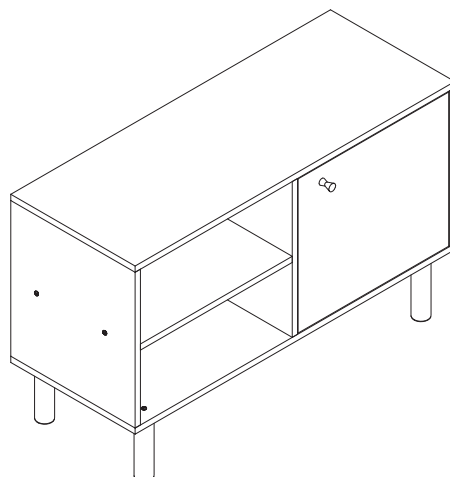

Antes de começar Before starting Antes de comenzar

Antes de começar a montagem prepare o ambiente, deixando-o completamente limpo e com bom espaço para iniciar o trabalho.

Prepare the room before starting the assembly, leaving it completely clean and the area in good condition to start the work.

Antes de comenzar el montaje preparar el ambiente, dejándolo completamente limpio y con bueno espacio para comenzar el trabajo.

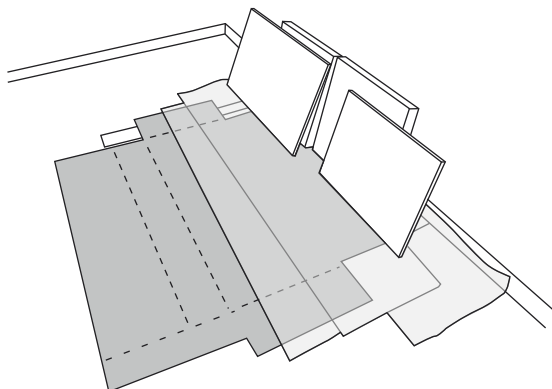

Utilize o papelão da própria embalagem para separar e apoiar as peças retiradas das caixas.

Use the cardboard of the packaging to separate and support the parts removed from the boxes.

Utilice el cartón de la embalaje para separar y apoyar las piezas desmontadas de las cajas.

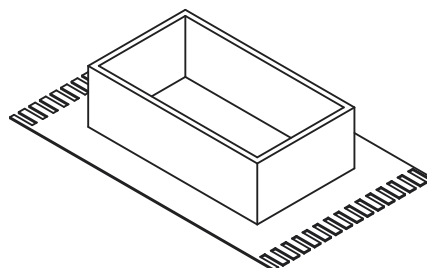

Forre a área de montagem com um cobertor ou tapete. Assim, você evita avarias nas peças durante o processo de montagem.

Cover the assembly area with a blanket or carpet to avoid damaging the parts during the assembly process.

Cubrir la zona de ensamble con una manta o alfombra. De este modo, se evitan daños en las piezas durante el proceso de montaje.



Evite acidentes Avoid accidents Prevenir accidentes

Solicitamos observar atentamente as orientações de montagem como: fixação do produto na parede, colocação de cola em locais específicos necessários, o peso suportado pelo produto, etc...

We request you to carefully observe the assembly instructions as: fixing the product on the wall, adding glue in needed and specific places, product weight limit, etc.

Pedimos que lea atentamente las instrucciones, principalmente las informaciones de fijación del producto en la pared, colocación de pegamento en local específico y necesario, el peso soportado por el producto etc...

Não escale ou se apoie no móvel.

Do not climb or lean on the furniture.

No se suba ni se apoye en el mueble.



Dimensões e ferramentas
Dimensions and tools
Dimensiones y herramientas

Dimensões:

L: 900 A: 560 P: 350 mm

Dimensions:

W: 35.43 H: 22.04 D: 13.77 inches

Dimensiones:

L: 900 A: 560 P: 350 mm

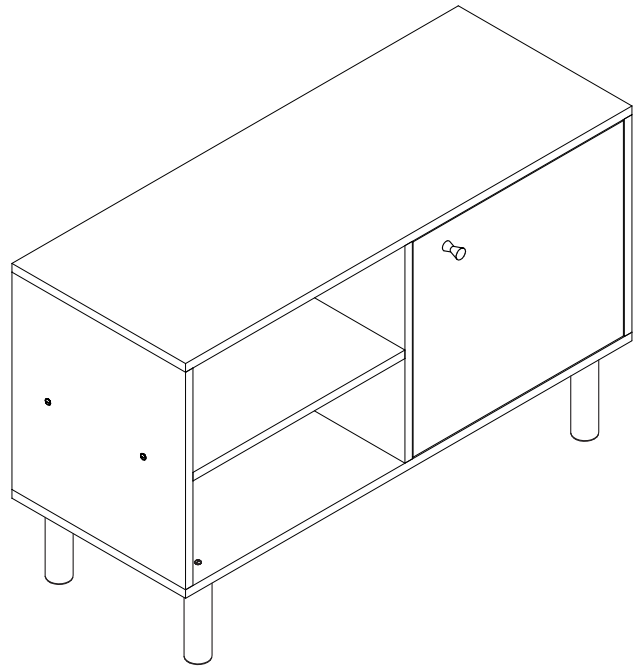

Limpeza
Cleaning
Limpieza

Pano levemente umedecido com água, seguido de pano seco, não utilizar produtos químico ou abrasivos.
You can clean the product with slightly dampened cloth followed by a dry cloth. Do not use chemicals or abrasives.
Solamente utilizar un paño húmedo y después un paño seco, no utilice productos químicos o abrasivos.

Todas as peças do móvel foram marcadas com um número. Antes de começar a montagem, identifique as peças numeradas em relação às instruções de montagem. Uma vez concluída a montagem, os números podem ser facilmente removidos com um pano ligeiramente embebido em álcool. Use álcool apenas para remover números das peças.

All the furniture parts have been marked with a number. Before you start assembling, please identify the numbered parts in relation to the assembly instructions. Once assembly is completed, the numbers can be easily removed with a cloth slightly damped in alcohol. Use alcohol only to remove part numbers.

Todos las piezas del mueble fueron marcadas con un número. Antes de empezar el montaje, identifique las piezas numeradas en relación con las instrucciones de montaje. Una vez que se completa el armado, los números se pueden quitar fácilmente con un paño ligeramente empapado en alcohol. Use alcohol solo para eliminar números de las piezas.

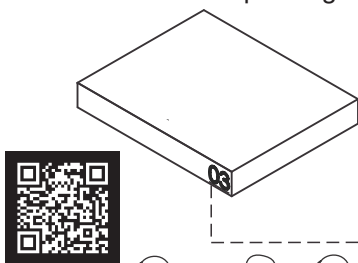

UTILIZE ALCOOL APENAS PARA REMOVER O NUMERO DAS PEÇAS
USE ALCOHOL ONLY TO REMOVE PART NUMBERS
UTILICE ALCOHOL SOLAMENTE PARA ELIMINAR EL NUMERO DE LAS PIEZAS

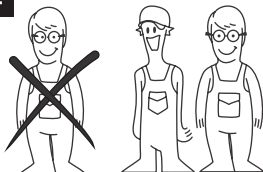

Para facilitar a montagem, utilize uma parafusadeira elétrica.
To speed assembly, use an electronic screwdriver.
Para facilitar el armado, utilice un destornillador eléctrico.

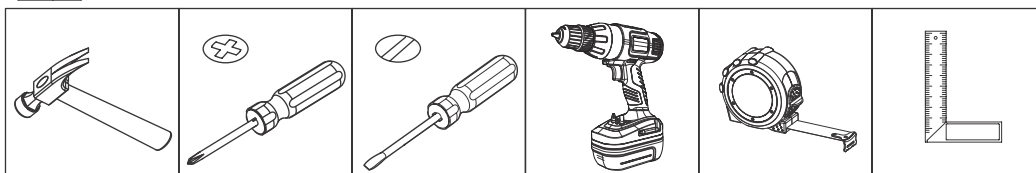

COD BR: BLC 63

PEÇA	DESCRIÇÃO	QUANT.
001	BASE	1
002	TAMPO	1
003	LATERAL ESQUERDA	1
004	LATERAL DIREITA	1
005	DIVISÓRIA	1
006	PRATELEIRA	1
007	PORTA	1
008	COSTA	2
009	PÉS	4

PART	DESCRIPTION	QTY
001	BASE	1
002	TOP	1
003	LEFT SIDE	1
004	RIGHT SIDE	1
005	PARTITION	1
006	SHELF	1
007	DOOR	1
008	BACK	2
009	FEET	4

PIEZA	DESCRIPCIÓN	CANTIDAD
001	BASE	1
002	TAPA	1
003	LATERAL IZQUIERDA	1
004	LATERAL DERECHA	1
005	PARTICIÓN	1
006	REPISA	1
007	PUERTA	1
008	REVÉS	2
009	PIES	4

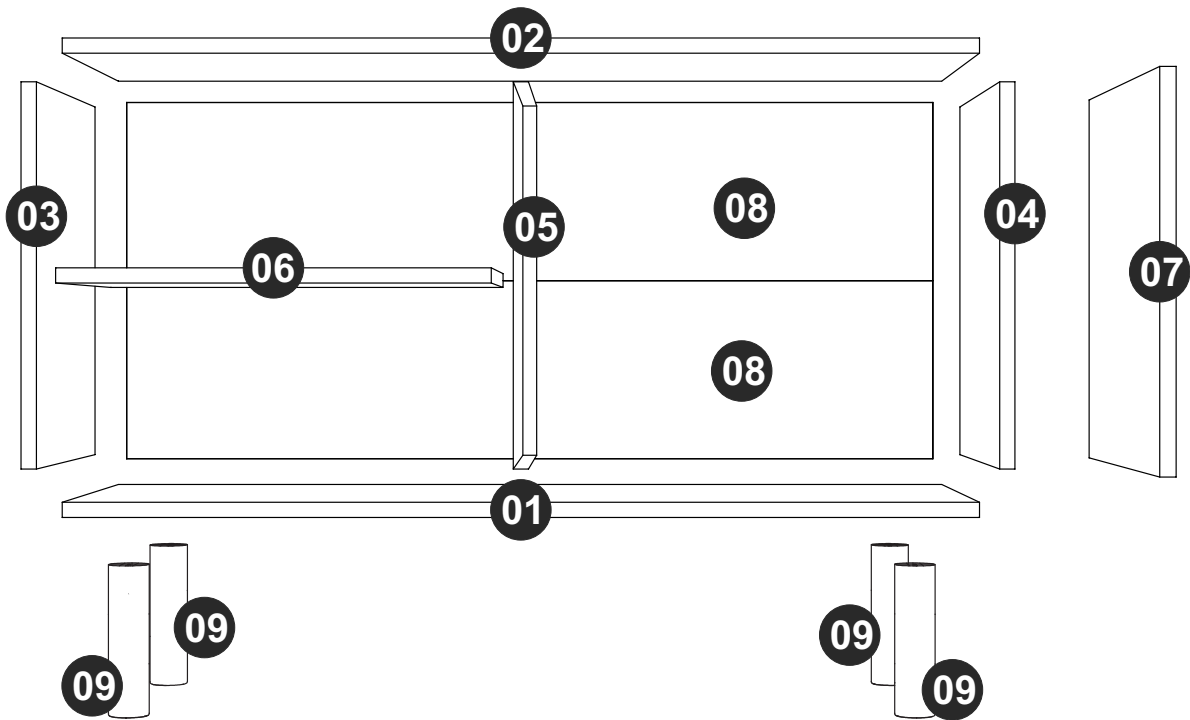

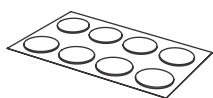

TAPA FUROS x 04
STICKER x 04
TAPAS PLÁSTICAS x 04



EF 000033 x 04
8x30



EF 000106 X 08
3,5x14 CC



EF 000113 x 01
3,5X30 CF



EF 000745 x 08
5X40

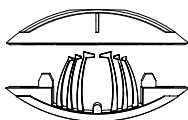

CLICK - 8



EF 000024 X 02

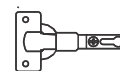

EF 000044 X 02



PUXADOR x 01
HANDLE x 01
MANIJA x 01

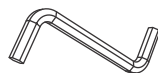

EF 000741 x 01

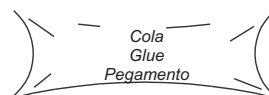

EF 000748 x 01



GIZ x 01
CHALK x 01
TIZA x 01

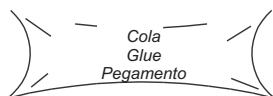

EF 000008 x 01

Utilize para medir as ferragens.

Utilice para medir el herraje.

Use for measuring the hardware.

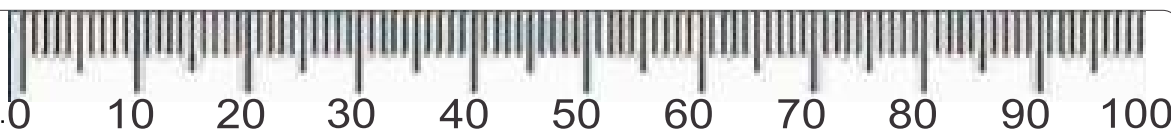

Garantia (exclusivo para o Brasil/exclusivo de Brasil/exclusive to Brazil):

A garantia dos produtos fabricados pela BRV Móveis, abrange eventuais defeitos-vícios de fabricação, no prazo estabelecido pelo código de Defesa do Consumidor, em seu artigo 26.II. o qual prevê a garantia de 90 (noventa) dias.

A = 11KG - 24.25 LB

B = 5KG - 11.02 LB

C = 4KG - 8.81 LB

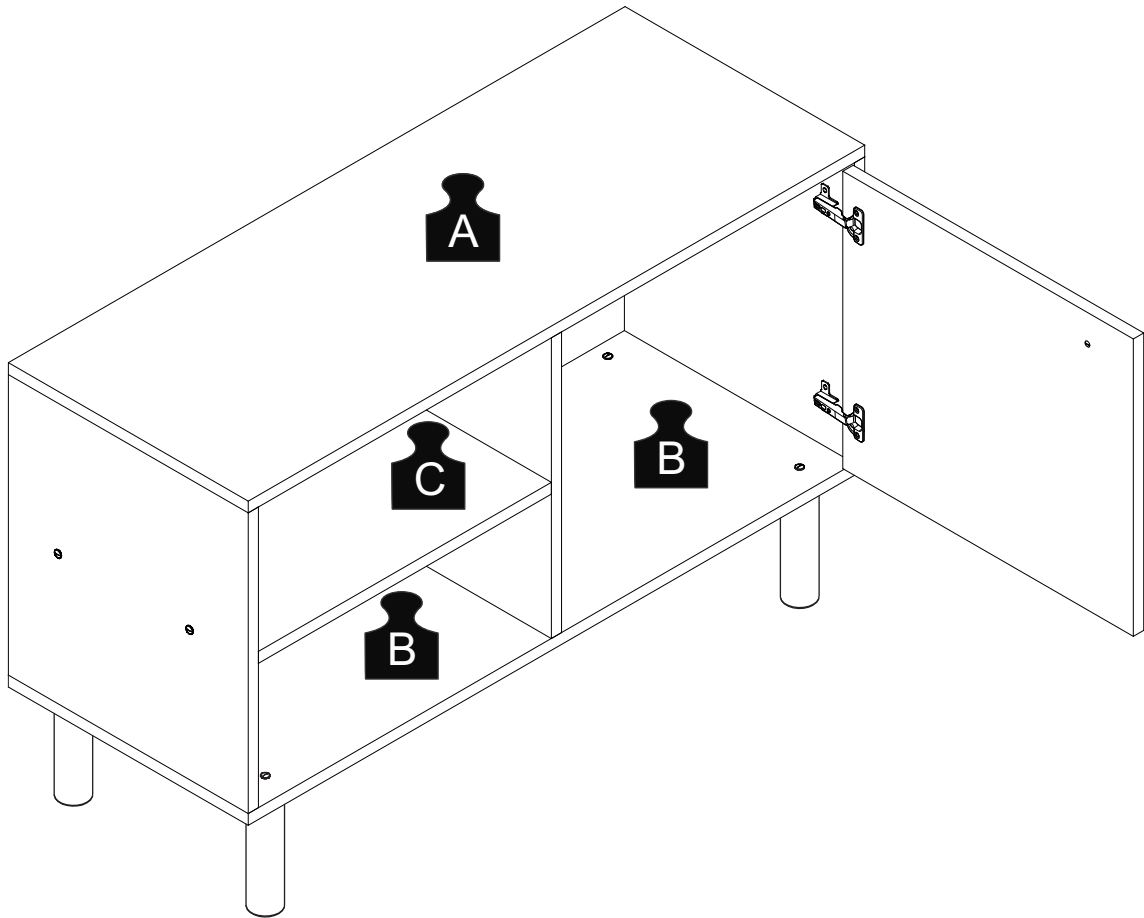

PASSO 1 / STEP 1 / PASO 1

Insira o click nas peças 01 e 02.
Insert the click into pieces 01 and 02.
Añade el click en las piezas 01 y 02.

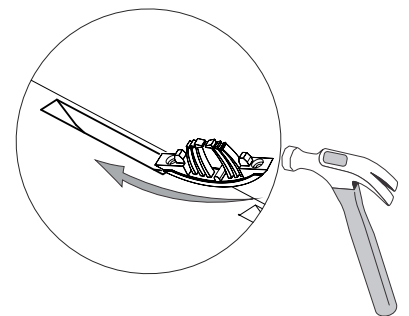

Se necessário, use o martelo para auxiliar.
If necessary use the hammer to help.
Si es necesario utilice el martillo para ayudar.

PASSO 2 / STEP 2 / PASO 2

Insira o click nas peças 03 e 04.
Insert the click into pieces 03 and 04.
Añade el click en las piezas 03 y 04.

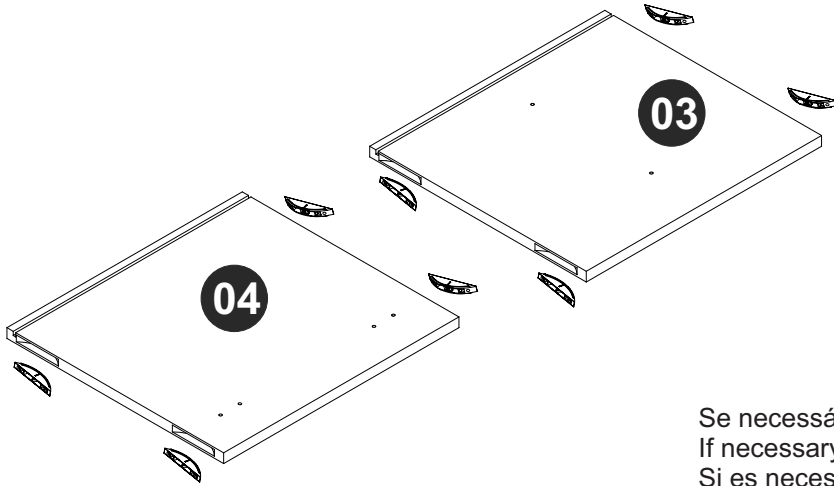

Se necessário, use o martelo para auxiliar.
If necessary use the hammer to help.
Si es necesario utilice el martillo para ayudar.

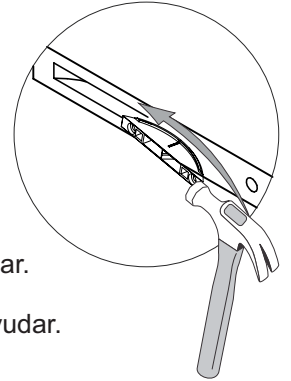

PASSO 3 / STEP 3 / PASO 3

Fixe a ferragem EF 000025 usando a ferragem EF 000106.
Fix hardware EF 000025 using hardware EF 000106.
Fije el herraje EF 000025 utilizando el herraje EF 000106.

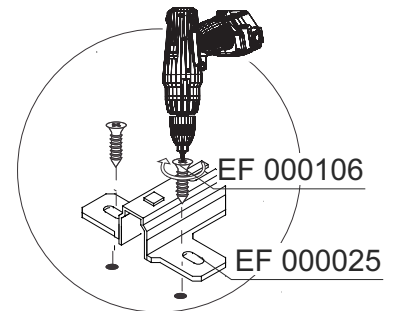
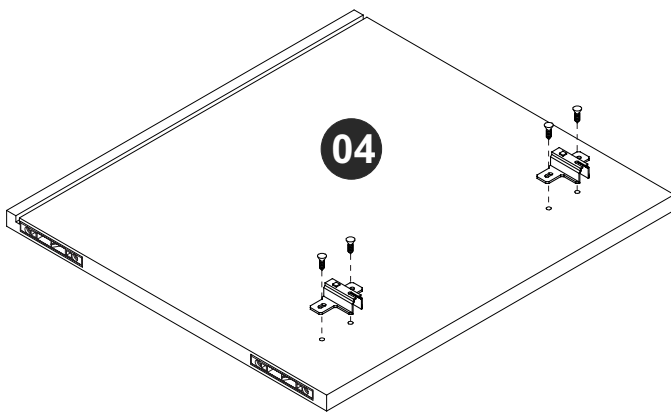

PASSO 4 / STEP 4 / PASO 4

Utilize a cola antes de inserir a ferragem EF 000033 na peça 05.
Fixe o suporte plástico na peça 05.
Use the glue before connecting hardware EF 000033 into piece 05.
Fix the plastic support into piece 05.
Utilice el pegamento antes de insertar herraje EF 000033 en la pieza 05.
Fije el soporte plástico en la pieza 05.

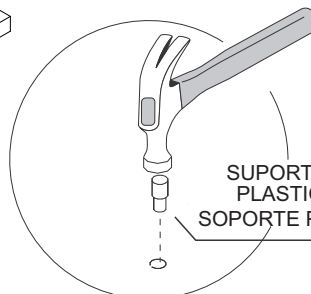
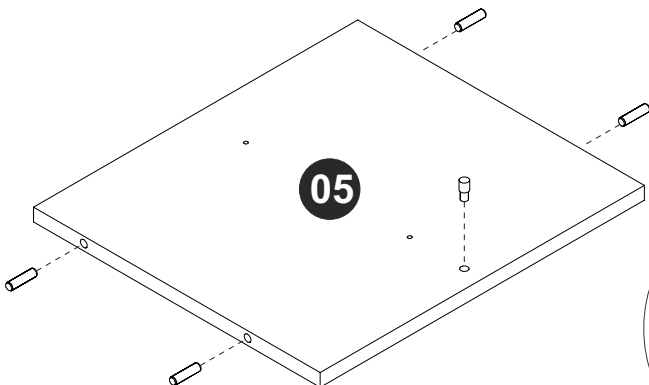

SUPORTE PLÁSTICO
PLASTIC SUPPORT
SOPORTE PLASTICO

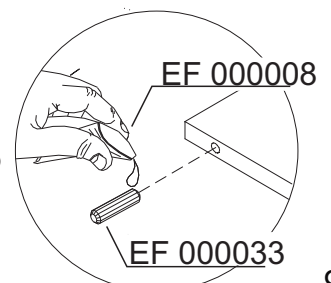

PASSO 5 / STEP 5 / PASO 5

Fixe o puxador usando a ferragem EF 000113. Fixe a ferragem EF 000043 usando a ferragem EF 000106.
Fix the handle using hardware EF 000113. Fix hardware EF 000043 using hardware EF 000106.
Fije la manija utilizando el herraje EF 000113. Fije el herraje EF 000043 utilizando el herraje EF 000106.

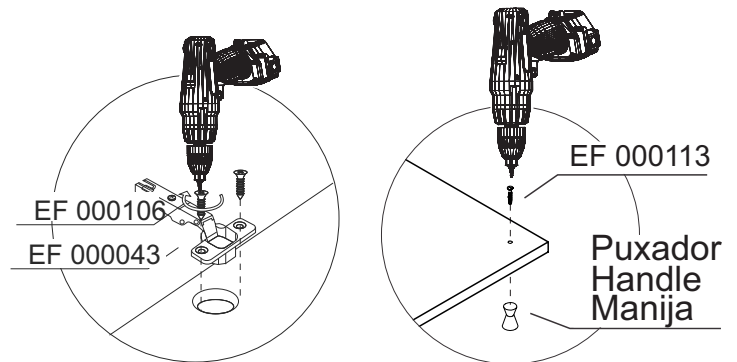
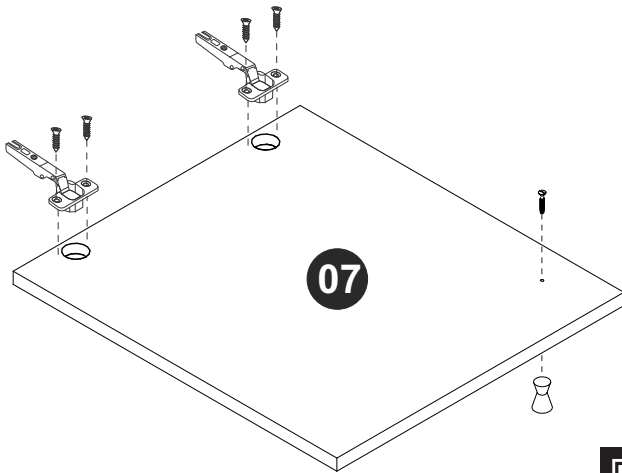

PASSO 6 / STEP 6 / PASO 6

Fixe a peça 06 nas peças 03 e 05 utilizando a ferragem EF 000745 e EF 000741.
Fix piece 06 into pieces 03 and 05 using hardware EF 000745 e EF 000741.
Fije la pieza 06 en las piezas 03 y 05 utilizando los herrajes EF 000745 e EF 000741.

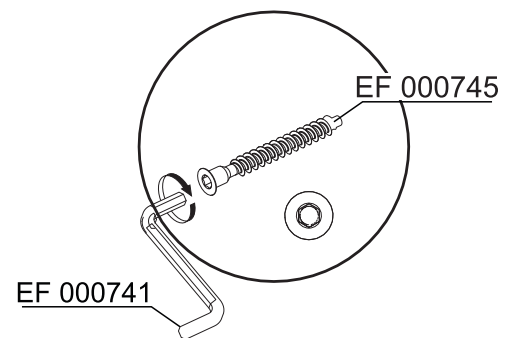
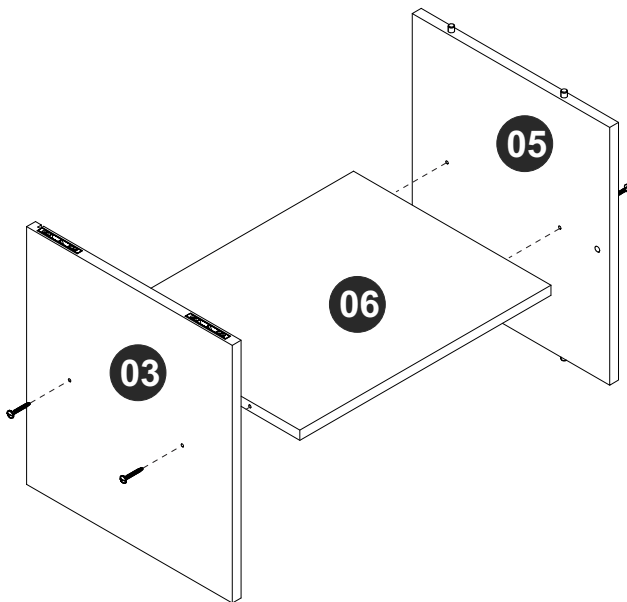

PASSO 7 / STEP 7 / PASO 7

Fixe os pés (peças 09) à peça 01 utilizando a ferragem EF 000745 e EF 000741.
Fix the feet (pieces 09) to piece 01 using hardware EF 000745 and EF 000741.
Fije los pies (piezas 09) en la pieza 01 utilizando los herrajes EF 000745 y EF 000741.

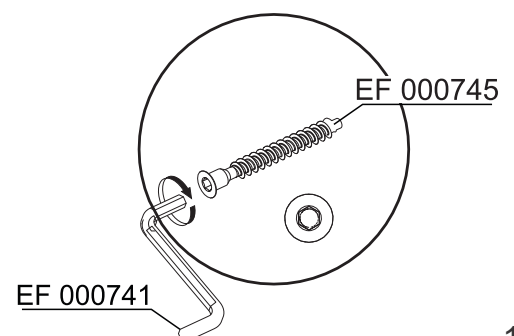
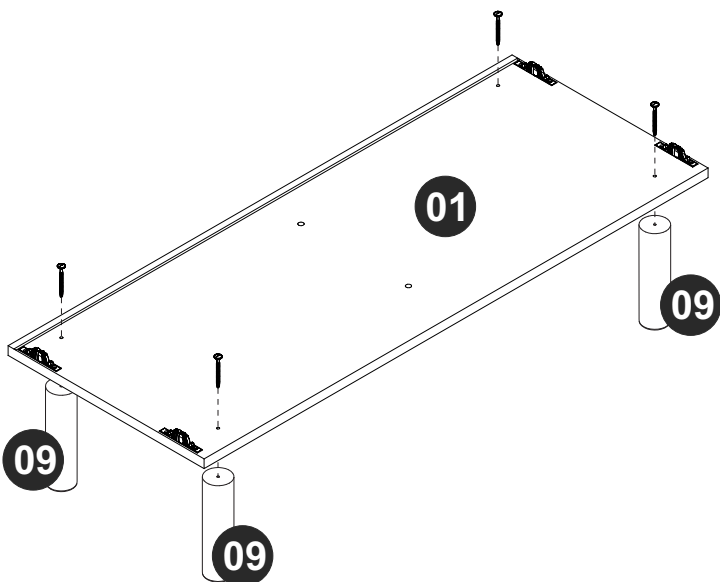

PASSO 8 / STEP 8 / PASO 8

Utilize a cola (EF 000748) antes de conectar a peça 01 à parte montada no passo anterior, encaixando os clicks.

Use the glue (EF 000748) before connecting piece 01 at part assembled on previous step, fitting the clicks.

Utilice el pegamento (EF 000748) antes de juntar la pieza 01 a la parte armada en el paso anterior, encajando los clicks.

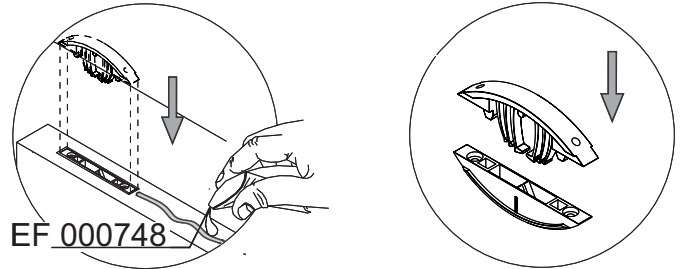
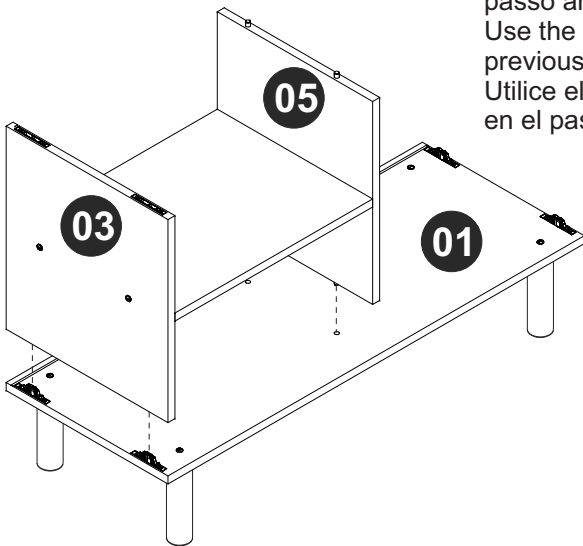

PASSO 9 / STEP 9 / PASO 9

Utilize a cola (EF 000748) antes de conectar a peça 04 à parte montada no passo anterior, encaixando os clicks.

Use the glue (EF 000748) before connecting piece 04 at part assembled on previous step, fitting the clicks.

Utilice el pegamento (EF 000748) antes de juntar la pieza 04 a la parte armada en el paso anterior, encajando los clicks.

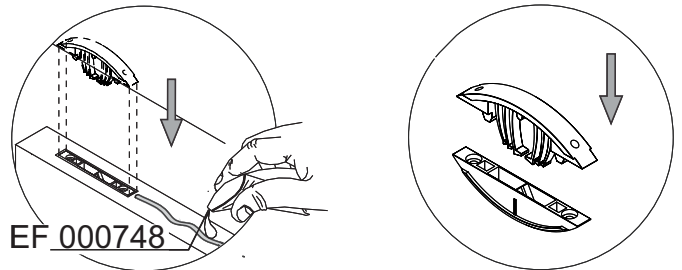
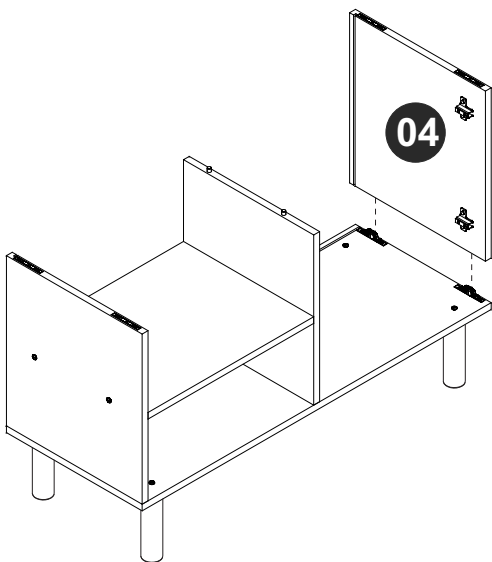

PASSO 10 / STEP 10 / PASO 10

Encaixe as peças 08 entre os espaços específicos nas peças 03 e 04.

Fix pieces 08 at part assembled through the specific spaces in pieces 03 and 04.

Fije las piezas 08 entre los espacios específicos en las piezas 03 y 04.

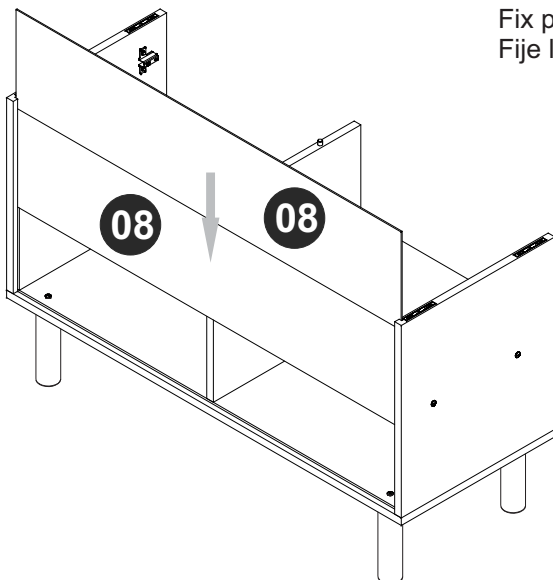

PASSO 11 / STEP 11 / PASO 11

Utilize a cola (EF 000748) antes de conectar a peça 02 a parte montada no passo anterior, encaixando os clicks.

Use the glue (EF 000748) before connecting piece 02 at part assembled on previous step, fitting the clicks.

Utilice el pegamento (EF 000748) antes de juntar la pieza 02 a la parte armada en el paso anterior, encajando los clicks.

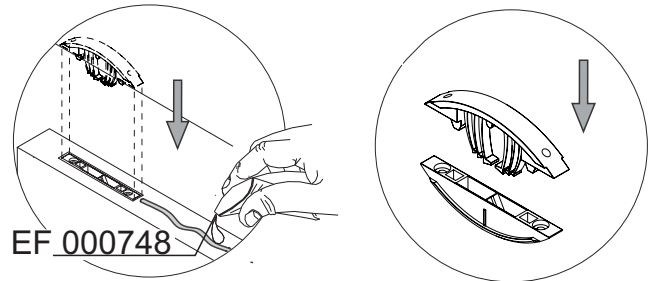
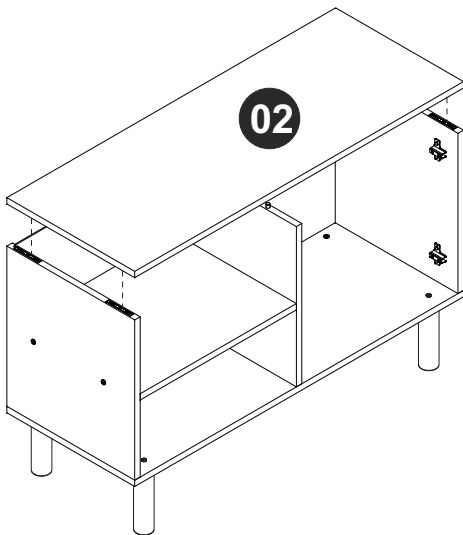

PASSO 12 / STEP 12 / PASO 12

Fixe a peça 07 ao móvel montado.

Attach piece 07 at the assembled furniture.

Fije la pieza 07 al mueble armado.

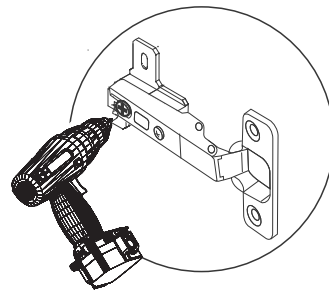
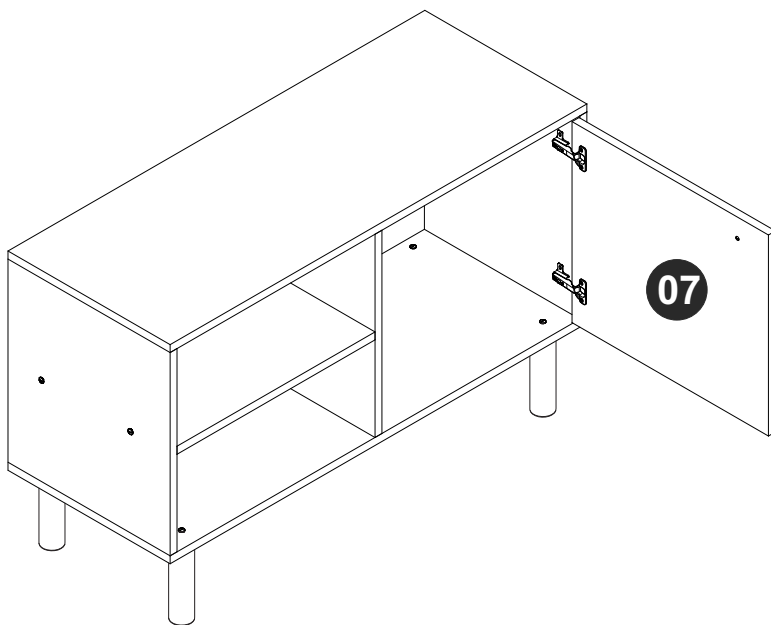

PASSO 13 / STEP 13 / PASO 13

Use o giz para dar o acabamento final ao produto.

Use os tapa furos para cobrir os parafusos aparentes.

Use the chalk to give the final finish on the product.

Use stickers to cover apparent screws.

Utilice la tiza para dar el acabado final al producto.

Utilice los tapa huecos para cubrir los tornillos aparentes.

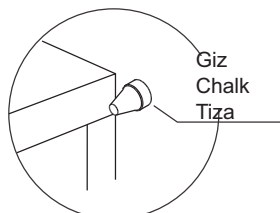
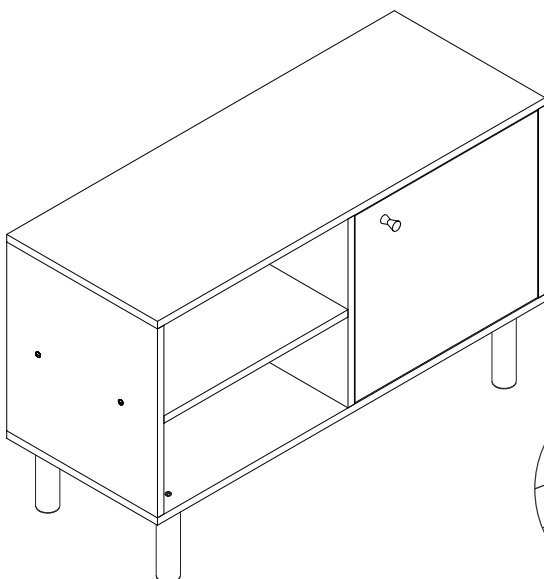

Giz
Chalk
Tiza

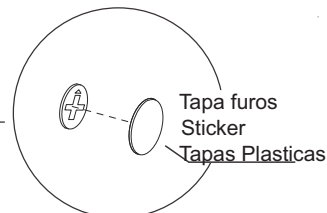

Tapa furos
Sticker
Tapas Plasticas

